



Metal Detecting Separator

SMS



Refer carefully to this manual before operation.

SMS Series

■ Coding Principle

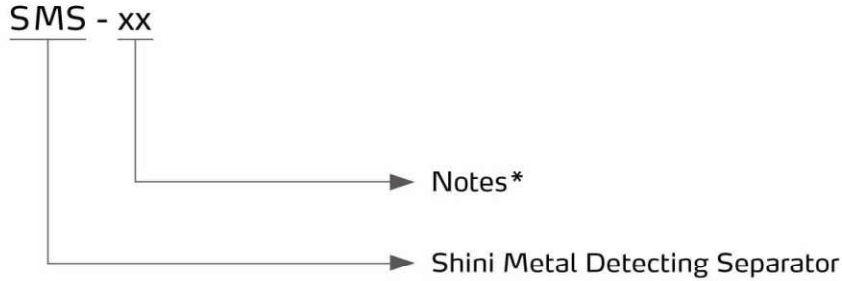

Notes:*

CE=CE Conformity

■ Features

Standard configuration

- Fast separating all the metals from the material.
- The minimum detectable diameter of the metals can be as short as 0.6mm.
- Compact design, easy to install and simple to operate.
- Mount directly on injection molding machine or extruder hoppers to protect facilities from the damage caused by hard metals.
- Standard equipped with a 12 liters hopper.

Accessory option

- Specific size of hoppers and floor stands can be customized to meet any requirements.



Metal Detecting Separator

■ Application

SMS series metal detecting separators are highly sensitive and accurate in detecting and separating metal grains, such as steel, iron, copper, aluminum, lead, tin, etc. Its principle is when metal impurities passing through it, electrical detector can send a signal to control board to open the valve to discharge the impurity materials. Pneumatic discharging system takes little space and ensures good performance. It can be installed directly on injection molding machine or (extruders) hoppers to protect the screw of machine from the damage caused by hard metals. Its processing capacity is ranging from 1,500L/hr to 3,000L/hr to meet any specific requirements.

Working Principle

Material discharge pipe has a ring-type metal detector sleeved on and when material with no metal impurities passing through it, no signal will be sent out from the detector to activate the separating flap from its standby position. Thus material will flow out via the passage showed in Fig. 1.

However when material with metal impurities passing through it, signal will be sent out from the detector to move the separating flap to the other position. Thus material will flow out via the passage showed in Fig. 2.

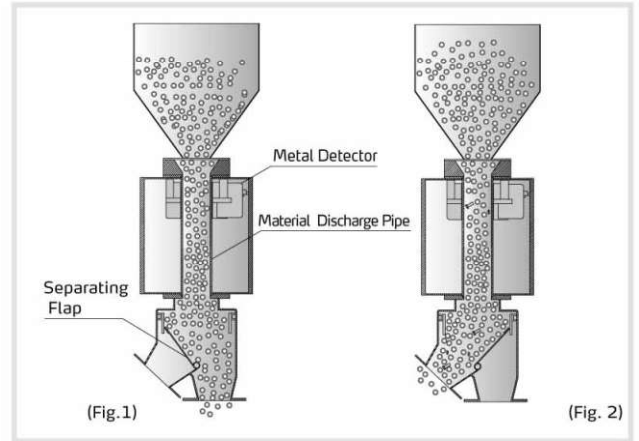

Outline Drawings

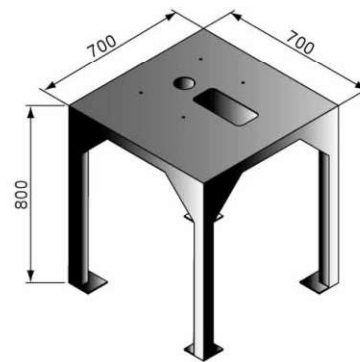
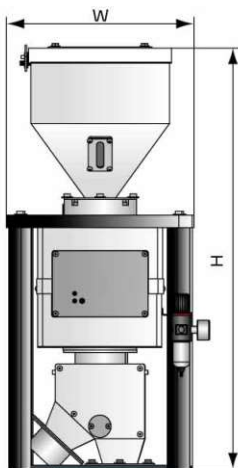

Floor Stand Dimensions

Specifications

Model	SMS-50	SMS-70
Maximum Throughput (L/hr)	1500	3000
Minimum Detectable Diameter (mm)	0.6	1.0
Material outlet pipe diameter (mm)	50	70
Dimensions (mm) H × W × D	850 × 400 × 370	850 × 400 × 370
Weight (kg)	50	50

- Notes: 1) Testing result of maximum throughput is based on particles of 0.8kg/L in bulk density and 2~3mm in size.
 2) The minimum metal diameter is detected based on carbon steel testing standard.
 3) Power supply: 1Φ, 115/230VAC, 50/60Hz.

We reserve the right to change specifications without prior notice.